

**MAGNA**  
600, 800 & 900 Series

**FEATURES**

Glasfloss Magna ASHRAE Series filters are designed to meet exact specifications in medium to high efficiency commercial or industrial applications. ASHRAE efficiency ranges include 600 Series: 60-65%, 800 Series: 80-85% and 900 Series: 90-95%. Glasfloss Magna ASHRAE filters are produced in a wide range of sizes, frame types and header combinations and are ideal for converting or upgrading existing systems.

**CONSTRUCTION**

Glasfloss Magna ASHRAE Series filters shall be manufactured with high efficiency glass microfiber media that is gently pleated to form the media pack. Rolled edge aluminum separators are inserted between each pleat to provide an extensive open-area for airflow and to stabilize the media pack. A heavy-duty 26 gauge galvanized metal frame or 3/4" particleboard frame shall encapsulate the media pack. The entire media pack is sealed to prevent air bypass. An optional gasket can be applied to the filter frame.

**APPLICATIONS**

Glasfloss Magna ASHRAE Series filters are designed for use where a high degree of cleanliness is required and contaminants must be removed to protect life, products or building interiors. The filters are ideal in a variety of applications including: hospitals, manufacturing plants, microelectronic component assembly, food processing, gas turbine, centrifugal compressor and high temperature processes.

**OPTIONS**

- **Turbine Style Magna** - available for gas turbine engine and centrifugal compressor applications.
- **High Temperature Magna** - available for drying ovens and other high temperature applications.

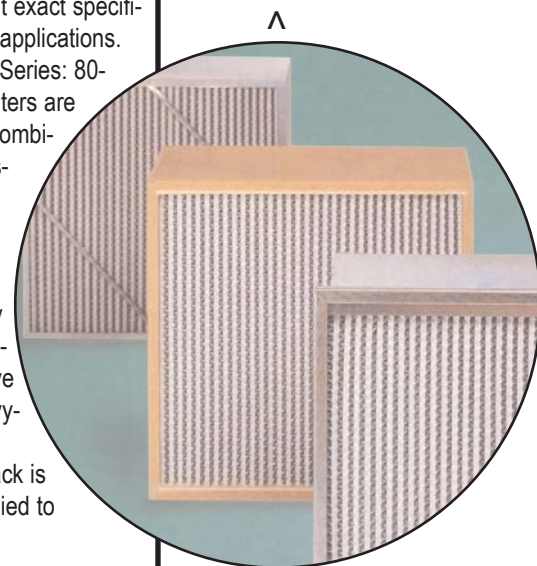

- V**
- High Efficiency Glass Microfiber
  - Heavy-duty 3/4" Particleboard or Galvanized Metal Frames
  - Sealed Media Pack
  - Optional 1/4" Thick Gasketing
  - High Capacity and High Temperature Filters Available

**SPECIFICATIONS**

The frame shall be made of a rigid high-density 3/4" particleboard or 26 gauge galvanized metal. The metal frame shall have two support struts on the air entering and the air leaving sides. A 26 gauge galvanized steel header is available on the metal frame and an aluminum header is optional for the particleboard frame. The media shall be constructed of a water resistant, inorganic glass microfiber. For quality assurance, the glass microfiber media rolls are randomly tested and certified to meet minimum efficiency requirements by the media manufacturer. The media pack shall consist of a continuous sheet of the pleated glass microfiber. The pleated media pack is separated with multiple rolled edge corrugated aluminum separators. The media cartridge shall be sealed with a fire retarding, rubber base, two-part sealant that bonds the media and separators to the interior of the particleboard frame filter. The media pack shall be pressure fitted with a fiberglass media gasket on metal frame filters. A 1/4" thick gasket shall be applied on the filter as an option. The filter shall be rated to withstand temperatures at a continuous 180 degrees Fahrenheit. The particleboard filters shall be rated Class 2 and metal frame filters Class 1 under U. L. Std. 900. The Magna Series shall have the following performance.

Series	600	800	900
Avg. Efficiency	60-65%	80-85%	90-95%
MERV	11	13	14

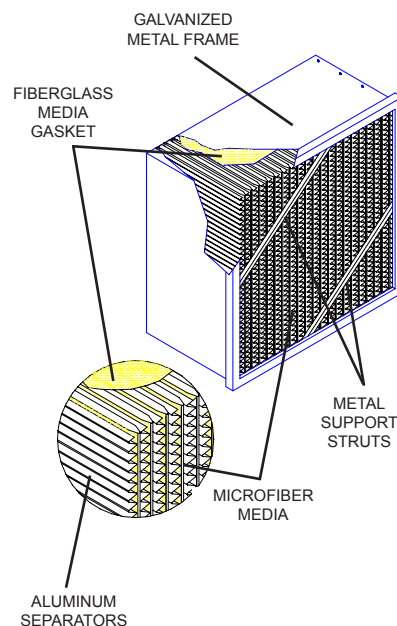

**"Serving You With Locations Throughout The Nation"**

Glasfloss has a policy of uninterrupted research, development and product improvement and reserves the right to change design and specifications without notice.

# MAGNA

600, 800 & 900 Series

## 600 Series: 60-65% & 800 Series: 80-85%

BASE MODEL NUMBER	SIZE H x W x D NOMINAL	SIZE H x W x D EXACT	RATED VELOCITY FPM	INITIAL RESIST. IN. W.G.		MEDIA SQUARE FEET	SIZE H x W x D NOMINAL MM	RATED VELOCITY M/H	INITIAL RESIST. PASCALS		
				65%	85%				65%	85%	
2016A1	2016A2	20 x 16 x 6	19-3/8 x 15-3/8 x 5-7/8	250	.20	.30	30.46	508 x 406 x 152	4575	49.7	74.6
2020A1	2020A2	20 x 20 x 6	19-3/8 x 19-3/8 x 5-7/8	250	.20	.30	38.67	508 x 508 x 152	4575	49.7	74.6
2412A1	2412A2	24 x 12 x 6	23-3/8 x 11-3/8 x 5-7/8	250	.20	.30	27.46	610 x 305 x 152	4575	49.7	74.6
2418A1	2418A2	24 x 18 x 6	23-3/8 x 17-3/8 x 5-7/8	250	.20	.30	41.85	610 x 457 x 152	4575	49.7	74.6
2420A1	2420A2	24 x 20 x 6	23-3/8 x 19-3/8 x 5-7/8	250	.20	.30	46.49	610 x 508 x 152	4575	49.7	74.6
2424A1	2424A2	24 x 24 x 6	23-3/8 x 23-3/8 x 5-7/8	250	.20	.30	55.46	610 x 610 x 152	4575	49.7	74.6
2516A1	2516A2	25 x 16 x 6	24-3/8 x 15-3/8 x 5-7/8	250	.20	.30	38.79	635 x 406 x 152	4575	49.7	74.6
2520A1	2520A2	25 x 20 x 6	24-3/8 x 19-3/8 x 5-7/8	250	.20	.30	48.19	635 x 508 x 152	4575	49.7	74.6
2016B1	2016B2	20 x 16 x 12	19-3/8 x 15-3/8 x 11-1/2	500	.50	.55	61.38	508 x 406 x 305	9150	124.4	136.8
2020B1	2020B2	20 x 20 x 12	19-3/8 x 19-3/8 x 11-1/2	500	.50	.55	76.24	508 x 508 x 305	9150	124.4	136.8
2412B1	2412B2	24 x 12 x 12	23-3/8 x 11-3/8 x 11-1/2	500	.50	.55	55.82	610 x 305 x 305	9150	124.4	136.8
2418B1	2418B2	24 x 18 x 12	23-3/8 x 17-3/8 x 11-1/2	500	.50	.55	82.4	610 x 457 x 305	9150	124.4	136.8
2420B1	2420B2	24 x 20 x 12	23-3/8 x 19-3/8 x 11-1/2	500	.50	.55	91.22	610 x 508 x 305	9150	124.4	136.8
2424B1	2424B2	24 x 24 x 12	23-3/8 x 23-3/8 x 11-1/2	500	.50	.55	110.91	610 x 610 x 305	9150	124.4	136.8
2516B1	2516B2	25 x 16 x 12	24-3/8 x 15-3/8 x 11-1/2	500	.50	.55	76.95	635 x 406 x 305	9150	124.4	136.8
2520B1	2520B2	25 x 20 x 12	24-3/8 x 19-3/8 x 11-1/2	500	.50	.55	95.16	635 x 508 x 305	9150	124.4	136.8

## 900 Series: 90-95%

BASE MODEL NUMBER	SIZE H x W x D NOMINAL	SIZE H x W x D EXACT	RATED VELOCITY FPM	INITIAL RESIST. IN. W.G.		MEDIA SQUARE FEET		SIZE H x W x D NOMINAL MM	RATED VELOCITY M/H	INITIAL RESIST. PASCALS	
				95%	HC	95%	HC			95%	HC
2016A3	20 x 16 x 6	19-3/8 x 15-3/8 x 5-7/8	250	.35	-	30.46	-	508 x 406 x 152	4575	87.1	-
2020A3	20 x 20 x 6	19-3/8 x 19-3/8 x 5-7/8	250	.35	-	38.67	-	508 x 508 x 152	4575	87.1	-
2412A3	24 x 12 x 6	23-3/8 x 11-3/8 x 5-7/8	250	.35	-	27.46	-	610 x 305 x 152	4575	87.1	-
2418A3	24 x 18 x 6	23-3/8 x 17-3/8 x 5-7/8	250	.35	-	41.85	-	610 x 457 x 152	4575	87.1	-
2420A3	24 x 20 x 6	23-3/8 x 19-3/8 x 5-7/8	250	.35	-	46.49	-	610 x 508 x 152	4575	87.1	-
2424A3	24 x 24 x 6	23-3/8 x 23-3/8 x 5-7/8	250	.35	-	55.46	-	610 x 610 x 152	4575	87.1	-
2516A3	25 x 16 x 6	24-3/8 x 15-3/8 x 5-7/8	250	.35	-	38.79	-	635 x 406 x 152	4575	87.1	-
2520A3	25 x 20 x 6	24-3/8 x 19-3/8 x 5-7/8	250	.35	-	48.19	-	635 x 508 x 152	4575	87.1	-
2016B3	20 x 16 x 12	19-3/8 x 15-3/8 x 11-1/2	500	.60	.55	61.38	73.66	508 x 406 x 305	9150	149.3	136.8
2020B3	20 x 20 x 12	19-3/8 x 19-3/8 x 11-1/2	500	.60	.55	76.24	91.49	508 x 508 x 305	9150	149.3	136.8
2412B3	24 x 12 x 12	23-3/8 x 11-3/8 x 11-1/2	500	.60	.55	55.82	66.98	610 x 305 x 305	9150	149.3	136.8
2418B3	24 x 18 x 12	23-3/8 x 17-3/8 x 11-1/2	500	.60	.55	82.4	98.88	610 x 457 x 305	9150	149.3	136.8
2420B3	24 x 20 x 12	23-3/8 x 19-3/8 x 11-1/2	500	.60	.55	91.22	109.46	610 x 508 x 305	9150	149.3	136.8
2424B3	24 x 24 x 12	23-3/8 x 23-3/8 x 11-1/2	500	.60	.55	110.91	133.09	610 x 610 x 305	9150	149.3	136.8
2516B3	25 x 16 x 12	24-3/8 x 15-3/8 x 11-1/2	500	.60	.55	76.95	92.34	635 x 406 x 305	9150	149.3	136.8
2520B3	25 x 20 x 12	24-3/8 x 19-3/8 x 11-1/2	500	.60	.55	95.16	114.19	635 x 508 x 305	9150	149.3	136.8

Tolerances shall be +/- 1/16" for height and width. The frame depth shall not exceed 5-7/8" and 11-1/2".

High Capacity 95% Magna filters contains 20% more media.

Performance values based on ASHRAE and in-house testing methods.

Recommended final resistance is 1.50" in. w.g.

### STANDARD PRESSURE DROP

Test Filter Size 24" x 24" x 12" Nominal

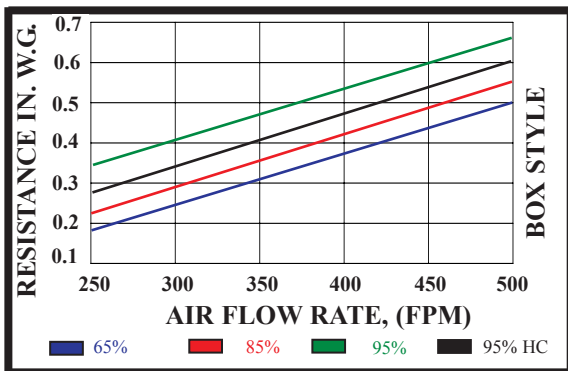

### MINIMUM PARTICLE SIZE EFFICIENCY

Test Filter Size 24" x 24" x 12" Nominal

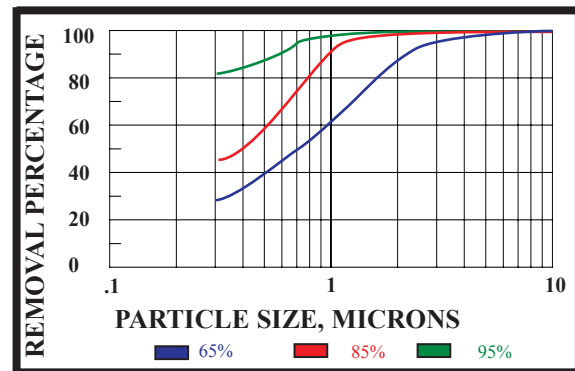

**PART NUMBER CONFIGURATION**

PREFIX	FRAME MATERIAL	FRAME STYLE	BASE MODEL NUMBER	GASKET LOCATION	FACE GUARDS	CAPACITY	
□ MAG	□ P = PARTICLE BOARD G = GALVANIZED METAL	□ B = BOX STYLE H = SINGLE HEADER D = DOUBLE HEADER	□ SELECT BASE MODEL NO. FROM CHART FOR DESIRED SIZE AND EFFICIENCY OR INSERT EXACT SIZE AND EFFICIENCY FOR SPECIAL SIZE MAGNA FILTERS	□ O = NO GASKET <b>BOX STYLE</b> A = AIR EXIT B = AIR ENTRY C = AIR EXIT/ENTRY D = SIDE LOAD <b>SINGLE HEADER</b> E = AIR ENTRY/EXIT F = AIR ENTRY H = AIR EXIT J = SIDE LOAD	□ <b>DOUBLE HEADER</b> K = AIR ENTRY/EXIT M = AIR ENTRY P = AIR EXIT Q = SIDE LOAD	□ X = NONE 1 = BACK SIDE 2 = FRONT SIDE 3 = BOTH SIDES	□ BLANK = REGULAR H = HI CAPACITY

**WOOD BOX**

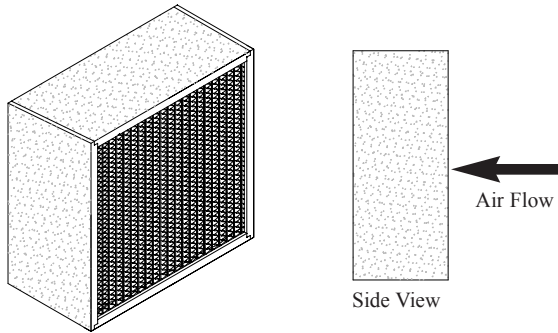

**METAL SINGLE HEADER**

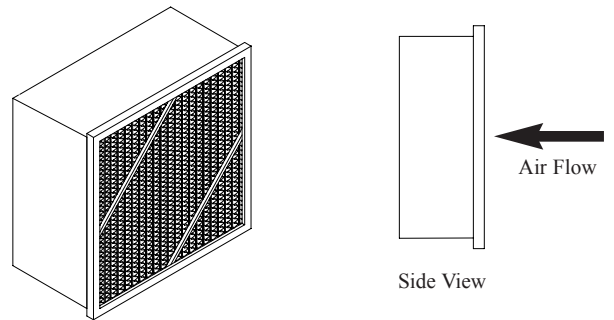

**METAL BOX**

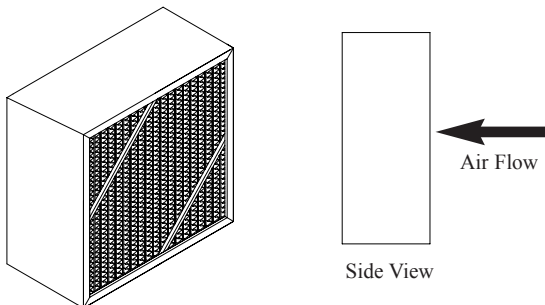

**METAL DOUBLE HEADER**

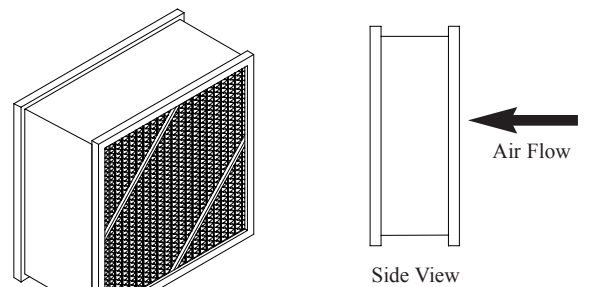

**"Serving You With Locations Throughout The Nation"**

Glasfloss has a policy of uninterrupted research, development and product improvement and reserves the right to change design and specifications without notice.

**Features:**

- Media produced from glass microfibers are moisture resistant and will not support microbial growth.
- Frame is available in either 3/4" particleboard or 26 gauge galvanized metal.
- Aluminum separators incorporate rolled edges that help prevent media chaffing and damage in handling.
- The filter cartridge is secured within the frame using a pressure fit fiberglass media gasket on metal frames and a two-part polyurethane sealant on particleboard frames to prevent air bypass.
- Magna 600, 800 and 900 series are available in standard and special size face dimensions.

**Optional Features:**

- An expanded metal wire lath face guard can be placed on air entry and/or the air leaving side of the filter.
- An aluminum header is available on particleboard frame.
- High temperature, high capacity and turbine style filters are available.
- A 1/4" thick gasket may be applied on the filter.



**SPECIFICATIONS FOR MAGNA SERIES**

Series	600	800	900
Avg. Efficiency	60-65%	80-85%	90-95%
MERV	11	13	14

The filter element shall be factory constructed by pleating a continuous sheet of glass microfiber media into uniform spaced pleats which are separated by rolled edge corrugated aluminum. The filter pack shall be encased in a rigid frame of 3/4" particleboard or 26 gauge galvanized metal. The media cartridge shall be sealed with a fire retarding, rubber base, two-part sealant that bonds the media and separators to the interior of the particleboard frame filter. The media pack shall be pressure fitted with a fiberglass media gasket on metal frame filters. The 26 gauge steel frames shall have two support struts on the air entry and air leaving sides. The frame shall not exceed 5-7/8" or 11-1/2" in depth and standard tolerances shall be +/- 1/16" on height and width. Each filter shall be packaged into a heavy-duty carton. The Magna ASHRAE 600, 800 and 900 Series filters shall be rated Class 2 and metal frame filters Class 1 under U. L. Std. 900.

Distributed by:

*for nation-wide delivery, please call or visit*

**FILTERA.com**

12999 Murphy Road, Suite I-1  
 Stafford, Texas 77477-3948  
 281.933.1100 Phone  
 888.933.0100 Toll Free Phone  
 281.933.1159 Fax

www.Filtera.com      info@Filtera.com



**"Serving You With Locations Throughout The Nation"**

Glasfloss has a policy of uninterrupted research, development and product improvement and reserves the right to change design and specifications without notice.