

Honeywell

enviraire®

Portable Air Purifiers

READ AND SAVE THESE INSTRUCTIONS
INSTALL PRE-FILTER BEFORE USE



Owner's Guide

For Model Series

50100 • 50150 • 50200 • 50250 • 50300

Air Cleaners

The Science of Clean Air®

IMPORTANT SAFETY INSTRUCTIONS

READ AND SAVE THESE SAFETY INSTRUCTIONS BEFORE USING THIS AIR CLEANER

When using electrical appliances, basic precautions should always be followed to reduce the risk of fire, electric shock, and injury to persons, including the following:

1. Read all instructions before operating the air cleaner.
2. Place air cleaner where it is not easily knocked over by persons in the household.
3. Always turn the air cleaner to the **OFF** position and unplug from the wall outlet when not in use.
4. To disconnect the air cleaner, first turn control to the **OFF** position, grip the plug and pull it from the wall outlet. Never pull by the cord.
5. Do not use any product with a damaged cord or plug or if product malfunctions, is dropped or damaged in any manner. Keep the cord away from heated surfaces.
6. Do not use air cleaner outdoors.
7. Never use air cleaner unless it is fully assembled.
8. Do not run power cord under carpets, and do not cover with throw rugs. Arrange cord such that it will not be tripped over.
9. Do not use air cleaner where combustible gases or vapors are present.
10. Do not expose the air cleaner to rain, or use near water, in a bathroom, laundry area or other damp location.
11. The air cleaner must be used in its upright position.
12. Do not allow foreign objects to enter ventilation or exhaust opening as this may cause electric shock or damage to the air cleaner. Do not block air outlets or intakes.
13. Locate air cleaner near the outlet and avoid using an extension cord.
14. This appliance has a polarized plug (one blade is wider than the other). To reduce the risk of shock, this plug is intended to fit only one way in a polarized outlet. If the plug does not fit fully in the outlet, reverse the plug. If it still does not fit, contact a qualified electrician. **DO NOT** attempt to defeat this safety feature.
15. A loose fit between the AC outlet (receptacle) and plug may cause overheating and a distortion of the plug. Contact a qualified electrician to replace loose or worn outlet.
16. Do not sit, stand or place heavy objects on the air cleaner.
17. Disconnect power supply before servicing.

WARNING: To Reduce The Risk of Fire or Electric Shock, Do Not Use This Air Cleaner With Any Solid-State Speed Control Device.

Congratulations

You now own a quality portable HEPA air cleaner that has been engineered and crafted for your satisfaction.

For Best Performance

We recommend that you operate your **Honeywell** air cleaner 24 hours a day because indoor air can be quickly contaminated by activity in a room, infiltration of outside air, and from other sources of contamination. While all the air in a room will not be processed by the air cleaner, the more air circulated through the filter, the more filtered air is returned to the room. Portable air cleaners will be much more effective in rooms where all doors and windows are closed.

It can be placed on the floor in almost any location. However, for best performance the air intake grille should not be blocked for at least 3 feet (1 meter) in all directions.

Note: Due to the large volume of air drawn towards the air cleaner, surrounding areas should be cleaned and/or vacuumed frequently to prevent dust buildup. If the unit is placed on a light colored carpeting, a small mat or rug should be used to ease cleaning and prevent any permanent staining of carpeting. This is particularly important in homes with heavier contamination from smoking or fireplaces.

Construction

Your **Honeywell** air cleaner has five basic components: the powerhead assembly (with controls and motor), the carbon pre-filter, the HEPA filter, the base assembly, and the locking mechanism.

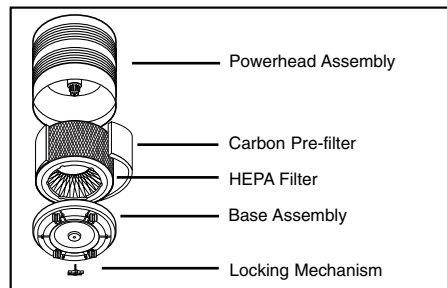

Operation

LOCATE PRE-FILTER IN THE BOX AND INSTALL BEFORE INITIAL OPERATION.
Refer to "How to Change the Filters" section for proper installation.

Model 50100 Series

The Honeywell Model 50100 is a 3 speed air cleaner operated by moving the speed control knob on the top panel from the Off (O) position to the High position. Allow the unit to operate for a few seconds at High speed, then leave the control knob in the High position for faster, more powerful room cleaning, or move the knob to the desired output setting:

III (high) – Maximum operation – fast initial cleaning
II (medium) – Daytime operation – fast fan speed
I (low) – Night-time – quieter operation
O (off)

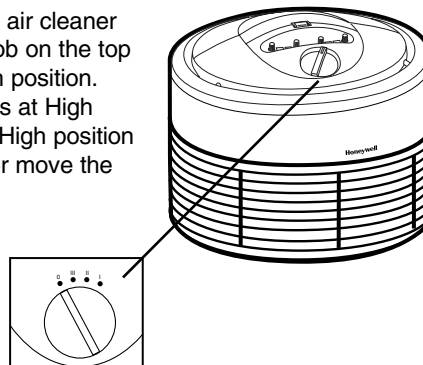

Models 50150, 50200, 50250, 50300 Series

The Honeywell Models 50150, 50200, 50250, 50300 are 3 speed air cleaners operated by moving the speed control knob on the top panel from the Off (O) position to the high (III) position. Allow the unit to operate for a few seconds at high speed, then leave the control knob in the high position for faster, more powerful room cleaning, or move the knob to a lower setting for quieter operation.

I (LOW)
II (MEDIUM)
III (HIGH)
O (OFF)

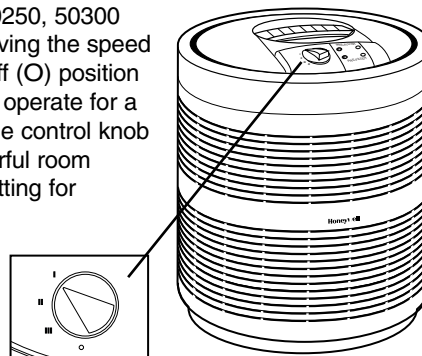

Filter Replacement

Caution: Do not attempt to wash either the carbon pre-filter or the HEPA filter. They are not washable and washing will damage the filters.

With proper maintenance, your **Honeywell** air cleaner is designed to provide years of high efficiency air cleaning. Our recommendations regarding filter replacement intervals are intended as guidelines only, as life expectancy of any filter media is dependent on the concentration of the contaminants to which the system is exposed. If there are sources of large amounts of contaminant generation (such as dust from woodworking or heavy smoking) the useful life of the filter media in your air cleaner may be reduced and require earlier replacement.

Whenever the air resistance of the HEPA filter becomes excessive due to the amount of contaminants it has captured, the air volume output will begin to reduce and the sound level of the air cleaner will increase.

The carbon pre-filter is the element of your air cleaner that helps reduce normal household odors, captures lint and other large particles and helps protect the HEPA filter. It should be replaced at least every 3 months. If there are heavy concentrations of odors, smoke, or large particles in the home, you may need to change the carbon pre-filter more often.

We **DO NOT** recommend operating the air cleaner without the carbon pre-filter or without following the filter replacement guidelines.

Filter Change Calendar

The air cleaner model 50100 series is equipped with a Filter Change Calendar wheel which serves as a convenient reminder for you to check and replace the pre-filter and HEPA filter based on the air cleaner's hours of use.

Upon starting your air cleaner and upon every pre-filter replacement, roll the pre-filter change calendar ahead three months to indicate when the next filter replacement is necessary. Upon starting your air cleaner and upon every HEPA filter replacement, roll the HEPA filter change calendar ahead one to three years (depending upon use) to indicate when filter replacement is necessary.

Intelli-Check™ Filter Monitors

The air cleaner model 50150, 50200, 50250, 50300 series are equipped with Intelli-Check™ Filter Monitors which serve as convenient reminders for you to check and replace the pre-filter and HEPA filter based on the air cleaner's hours of use. The monitors have the ability to indicate the amount of expected filter life used. Once a filter has reached the end of its expected life, its light will remain on until it is RESET. You may unplug the air cleaner without interrupting the filter monitors.

The Intelli-Check™ Filter Monitors will indicate replacement of the pre-filter and the HEPA filter. Depending upon your individual usage (environment and hours used), you may need to check and replace the filters more or less frequently.

To check Expected Filter Life Usage

When the unit is turned on, quickly press the appropriate filter monitor button. The pre-filter light will flash up to 3 times and the HEPA filter light will flash up to 4 times, depending upon how much expected filter life has been used.

PREFILTER:

- 1 flash = from new, up to 1/3 expected life used up
- 2 flashes = between 1/3 and 2/3 expected life used up
- 3 flashes = between 2/3 and all of expected life used up
- Remains on = time to check/replace pre-filter

HEPA FILTER:

- 1 flash = from new, up to 1/4 expected life used up
- 2 flashes = between 1/4 and 1/2 expected life used up
- 3 flashes = between 1/2 and 3/4 expected life used up
- 4 flashes = between 3/4 and all of expected life used up
- Remains on = time to check/replace HEPA filter

To RESET Filter Monitor

When the filter monitor light remains on, it is time to check/replace the filter and reset the filter monitor, if needed. With the unit powered on, press and hold the appropriate filter monitor button down for approximately 5 seconds until the light turns off. Depending upon your individual usage (environment and hours used), you may need to check and replace the filters more or less frequently.

Replacement Filters

Select the proper replacement filter for your Honeywell HEPA air cleaner from the chart below:

<u>Model No.</u>	<u>HEPA Filter Part Number</u>	<u>Carbon Pre-filter Part Number</u>
50100	20590	38002
50150	21500	38002
50200	23500	38002
50250	24000	38002
50300	29500	38002

Replacement filters may be purchased from the retail store or ordered from the dealer where you purchased the product. If you cannot locate one in your area, email us at honeywell@protocolusa.com or visit us at www.honeywellconsumerproducts.com.

How to Change the Filters

CAUTION: DISCONNECT FROM POWER SUPPLY BEFORE SERVICING
Do not attempt to wash either the carbon pre-filter or the HEPA filter. They are not washable and washing will damage the filters.

The only two parts requiring any service are the carbon pre-filter and the HEPA filter. No tools are needed. To change either filter, disassemble the unit as shown below:

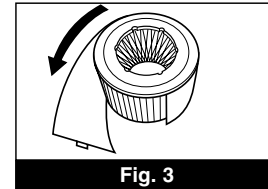
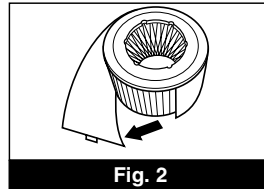
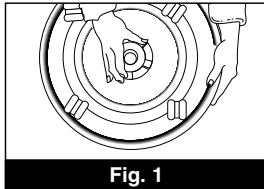

Step 1: Turn the air cleaner off and unplug from the wall outlet.

Step 2: To open, gently place the air cleaner on its side and unscrew the locking mechanism located under the base assembly (Fig. 1).

Step 3: Remove the base assembly from the air cleaner.

Step 4: Remove the filter assembly (consisting of the HEPA filter and pre-filter) from the internal chamber.

Step 5: Locate the seam of the pre-filter and carefully separate the fastener to remove the pre-filter from the HEPA filter (Fig. 2).

Step 6: Discard used filter(s) being replaced. Remove any packaging and plastic from the replacement filter(s).

Step 7: Carefully wrap the pre-filter around the HEPA filter so that the ends meet (Fig. 3). Fasten the ends together with the fastener provided.

Step 8: Place the whole filter assembly into the internal chamber. Close the product by replacing the base and tightening the locking mechanism.

Step 9: Turn the air cleaner into an upright position, plug into a wall outlet and it is ready for operation.

Storage

If you store your **Honeywell** HEPA air cleaner for more than 30 days, we recommend:

- Removing both the primary HEPA filter and the carbon pre-filter from the unit.
- Discarding the pre-filter.
- Wrapping the HEPA filter in an air-tight plastic bag or plastic wrap. Be sure that the filter is totally sealed.
- To restore the air cleaner to service, unwrap the HEPA filter, install a new carbon pre-filter, and reinstall both filters in the air cleaner. See "How to Change the Filters" section for proper installation.

Troubleshooting

- Start on HIGH for a few minutes, then adjust to desired speed.
- This product may emit a “new” smell which will disappear over a relatively short period of operation.
- Check to make sure that the power cord is correctly connected to the outlet.
- Test that the outlet is functioning properly using another appliance or lamp.
- Check the fuse or circuit breaker. The outlet may be overloaded if other appliances are also in use. Determine and correct the cause of the overload.
- If none of the above procedures restore operation, return your unit to the store. If the store’s return policy does not allow the return, return the complete unit per the instructions in the warranty section of this owner’s guide. Do not attempt to repair the unit yourself as it may cause injury, and the warranty does not cover damage resulting from unauthorized attempts to repair or from any use not in accordance with this manual.

Five Year Limited Warranty

Honeywell HEPA Air Cleaners
Model Series Nos. 50100, 50150, 50200, 50250, 50300

This product has been engineered and crafted with great care for your satisfaction.
Be sure to fill out and return the enclosed card within 10 days of purchase.

A. This limited warranty applies to repair or replacement of product found to be defective in material or workmanship within 5 years of the date of purchase. This warranty does not apply to damage resulting from commercial, abusive, or unreasonable use. Defects that are the result of normal wear and tear will not be considered manufacturing defects under this warranty. **HONEYWELL IS NOT LIABLE FOR INCIDENTAL OR CONSEQUENTIAL DAMAGES OF ANY NATURE. ANY IMPLIED WARRANTY, INCLUDING MERCHANTABILITY OR FITNESS FOR A PARTICULAR PURPOSE, ON THIS PRODUCT IS LIMITED IN DURATION TO THE DURATION OF THIS LIMITED WARRANTY.** Some regions do not allow the exclusion or limitation of incidental or consequential damages or limitations on how long an implied warranty lasts, so the above limitations or exclusions may not apply to you. This warranty gives you specific legal rights, and you also may have other rights which vary from region to region. **This warranty applies only to the original purchaser of this product.**

B. At its option, Honeywell will repair or replace this product if it is found to be defective in material or workmanship. Defective product should be returned to the place of purchase in accordance with store policy or to Honeywell.

C. This warranty does not cover damage resulting from unauthorized attempts to repair or from any use not in accordance with this manual.

D. This warranty **DOES NOT** cover the filter cartridge except for material or workmanship defects.

E. Return defective product to the following address with a brief description of the problem. Include proof-of-purchase and a U.S. \$10.00/ Canadian \$15.00 check or money order for handling, return packing and shipping charges. Please include your name, address and daytime phone number. You must prepay shipping charges. Mark carton **“Attention Returns Department”**

Ship to:

In USA:

Honeywell
Returns Department
4755 Southpoint Drive
Memphis, TN 38118 U.S.A.

In Canada:

Honeywell
510 Bronte St. South
Milton, Ontario Canada L9T 2X6

If you experience a problem with your Air Cleaner, please see owner’s guide for instructions. Please do not attempt to repair the air cleaner yourself. Doing so may void the warranty and could cause damage or personal injury. If the problem still persists, please call:

Honeywell
Consumer Relations Dept.
Toll free 1-800-332-1110
E-mail: honeywell@protocolusa.com

Mail Questions or Comments to:

Honeywell
Consumer Relations Dept.
250 Turnpike Road
Southborough, MA 01772 U.S.A.
Or e-mail us at honeywell@protocolusa.com

Visit our website at www.honeywellconsumerproducts.com

